

Technical data sheet

Wall and support bracket AW 15 2L

Item number: 6420912



Wall and support bracket with welded head plate and two fastening holes.
The double-perforated bracket offers the special option of double anchoring on
lightweight partitions and light masonry.



St Steel

FT Hot-dip galvanised

Master data

Item number	6420912
Type	AW 15 16 FT 2L
Description 1	Wall and support bracket
Description 2	with 2 fastening holes
Manufacturer	OBO
Dimension	B160mm
Material	Steel
Surface	Hot-dip galvanised
Surface standard	DIN EN ISO 1461
Smallest sales unit	1
Unit of quantity	Piece
Weight	20 kg
Weight unit	kg/100 pc.

Technical data sheet

Wall and support bracket AW 15 2L

Item number: 6420912



Dimensions

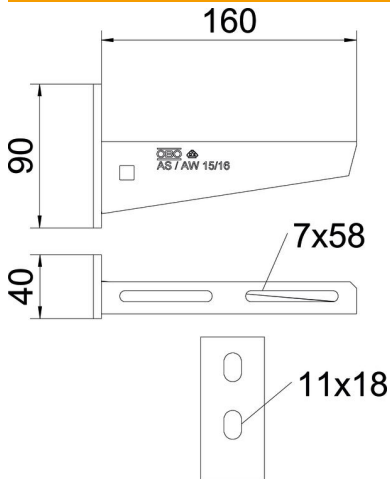

Width	160 mm
Width	6 in
Height	2.12 in
Dimension A	40 mm
Dimension B	160 mm
Dimension H	54 mm

Chara

Die ange
achten!

Technical data

Version for	Wall and support bracket
F in kN	1.5 kN
Maintain electrical functions	no
Hole diameter	11 mm
Rustproof steel, pickled	no
Angle range, max.	90 mm
Angle range, min.	90 mm

Loads

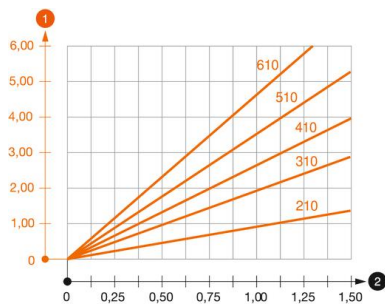

Load diagram, bracket, type AW 15

- 1 Bending of the bracket tip at permitted bracket load
- 2 Permitted bracket load in kN without man load
- Load curve with bracket lengths in mm