

Technical data sheet

Fastening panels

Item number: 6288007

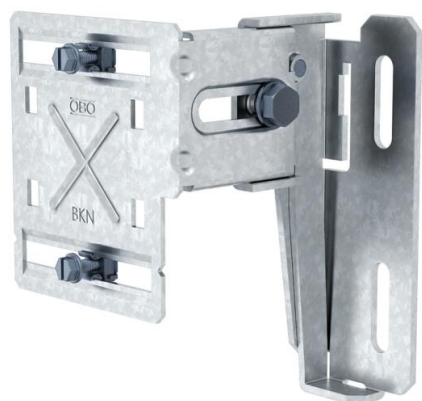

Fastening panel for mounting device installation trunking on skirting board constructions and as a support for the convection grid. The fastening panel can be used for all Rapid 80 device installation trunking systems of type GK and GA. When mounting plastic GK device installation trunking, the matching wall panel adapter is also required. The connection profile is required for mounting double trunking of type GS-D70170 and GS-D90170, as well as for GS trunking with a nominal width of 210 mm.

The mesh slats are simply attached to the slat holder.



St Steel

FS Strip galvanized

Master data

Item number	6288007
Type	BKN200 350
Description 1	Fixing panel
Description 2	depth 198-351
Manufacturer	OBO
Dimension	140x128x351
Material	Steel
Surface	Strip galvanized
Surface standard	DIN EN 10346
Smallest sales unit	1
Unit of quantity	Piece
Weight	89 kg
Weight unit	kg/100 pc.

Technical data sheet

Fastening panels

Item number: 6288007



Dimensions

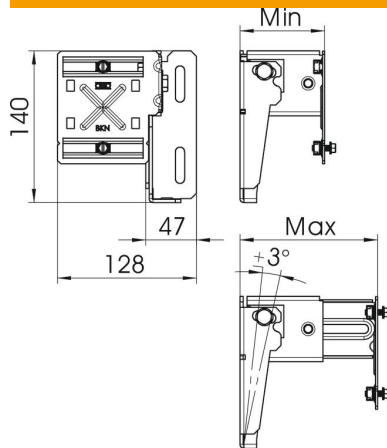

Length	351 mm
Width	128 mm
Height	140 mm

Technical data

Version for	198–351 mm
Version for	Wall mounting
Fastening type	Screw-on
Trunking mounting	Screw
Spacing from wall, max.	351 mm
Spacing from wall, min.	198 mm