

# Technical data sheet

## Cable tray MKS-Magic® 110

Item no. 6059179

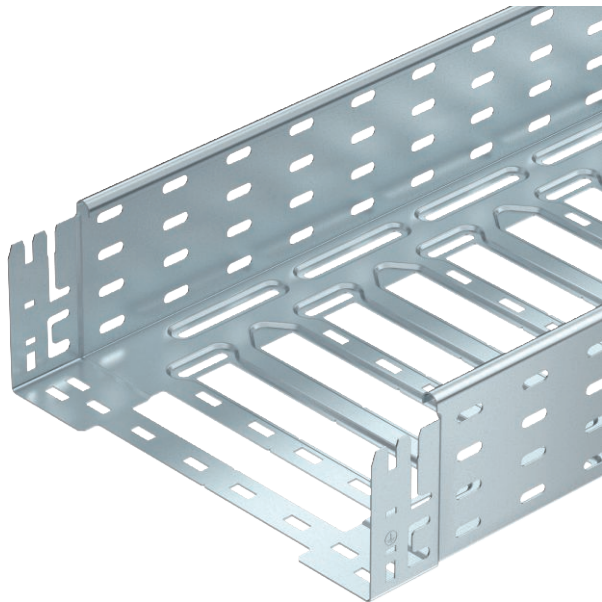

Cable tray with integrated quick fastening system. The usable length of the cable tray is 3,000 mm.  
 The cable tray has continuous side perforations of 7 x 20 mm for the installation of additional connection and mounting components.  
 From a cable tray width of 200 mm with 30% hole surface, suitable for use under sprinkler systems according to VdS guideline 2092.  
 Continuous equipotential bonding is guaranteed without additional components.



- St** Steel
- FT** Hot-dip galvanised

### Master data

Item no.	6059179
Type	MKSM 130 FT
Description 1	Cable tray MKSM
Description 2	perforated, quick connector
Manufacturer	OBO
Dimension	110x300x3050
Material	Steel
Material symbol	St
Surface	Hot-dip galvanised
Surface to DIN	DIN EN ISO 1461
Surface symbol	FT
Smallest sales unit (VG)	3 m
Weight	363,97 kg/100 m

### Technical data

	Usable cross-section	32.800,00 mm <sup>2</sup>
	Usable cross-section	328,00 cm <sup>2</sup>
	Suitable for maintaining electrical function	<input type="checkbox"/>
	Connector version	Integrated connector
	With cover	<input type="checkbox"/>
	Mounting perforation in base	<input checked="" type="checkbox"/>
	NATO hole pattern	<input type="checkbox"/>
	Rustproof steel, pickled	<input type="checkbox"/>
	Side perforation	<input checked="" type="checkbox"/>
	Wide-span version	<input type="checkbox"/>

# Technical data sheet

## Cable tray MKS-Magic® 110

Item no. 6059179



### Technical data

#### Dimensions

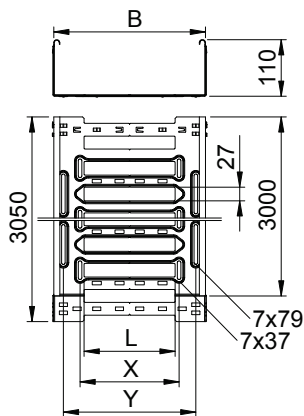

Length	3.050,00 mm
Width	300,00 mm
Height	110,00 mm
Side height	110,00 mm
Dimension B	300,00 mm
Dimension L	180,00 mm
Dimension x	196,00 mm
Dimension y	262,00 mm
Plate thickness	1,00 mm

#### Appr. load:

Support spacing 1.5 m	1,80 kN/m
Support spacing 2.0 m	1,30 kN/m
Support spacing 2.5 m	0,93 kN/m
Support spacing 3.0 m	0,70 kN/m

Load diagram, cable tray, type MKSM 110

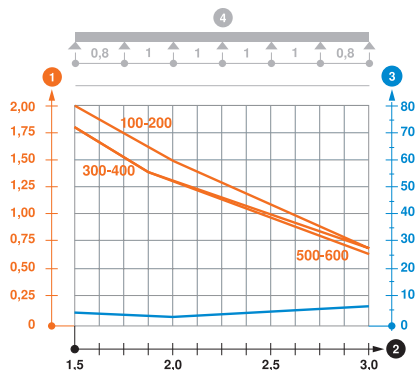

- 1 Permitted cable tray/ladder load in kN/m without man load
- 2 Support width in m
- 3 Rail bend in mm at permitted kN/m
- 4 Load scheme during testing
- Load curve with cable tray/ladder width in mm
- Strut bend curve according to support width