

# Technical data sheet

## Wall and support bracket MWAG 12 A2

Item number: 6424404



Light-duty wall and support bracket with edged design for screwless mesh cable tray fastening.  
Including truss-head bolt M10 x 25 for fastening to U supports.  
Including truss-head bolt M10 x 25 for fastening to U supports.



**A2** Stainless steel

**2B** Bright, treated

### Master data

Item number	6424404
Type	MWAG 12 31 A2
Description 1	Wall and support bracket
Description 2	for mesh cable tray
Manufacturer	OBO
Dimension	B310mm
Material	Stainless steel
Surface	Bright, treated
Surface standard	
Smallest sales unit	1
Unit of quantity	Piece
Weight	51.8 kg
Weight unit	kg/100 pc.

# Technical data sheet

## Wall and support bracket MWAG 12 A2

Item number: 6424404



### Dimensions

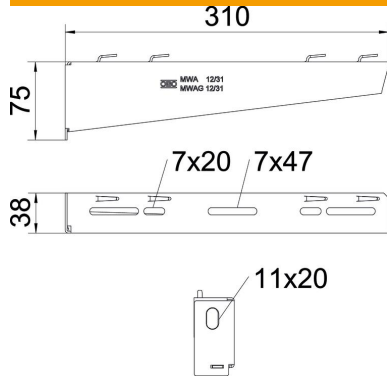

Length	38 mm
Width	310 mm
Width	12 in
Height	75 mm
Height	2.95 in
Dimension A	38 mm
Dimension B	310 mm
Dimension H	75 mm
Dimension L	310 mm

### Technical data

Version for	Wall and support bracket
F in kN	1.2 kN
Maintain electrical functions	no
for width min.	300
Hole diameter	11 mm
Rustproof steel, pickled	no
Angle range, max.	90 mm
Angle range, min.	90 mm

### Characteristic anchor load values for wall and support bracket MWAG 12

Wall fastening	Max. load [kN]			
	Bracket width [mm]			
Anchor type	110	210	310	410
BZ3 10x90/0-30	1.2	1.2	1.2	1.2

Die angegebenen Werte basieren auf ungerissenen Beton der Festigkeitsklasse C20/25. Die Einbaubedingungen der ETA-Zulassung (Dübel) sind zu beachten!

### Load values for MWAG 12 on suspended support

Support	Max. total load F in kN			
	Bracket length in mm			
	100	200	300	400
US 3 K/ 20 - 60	1.2	1.2	1.2	1.2
US 3 K/ 70 - 120	1.2	1.2	1.2	1.2
US 5 K/ 20 - 60	1.2	1.2	1.2	1.2
US 5 K/ 70 - 120	1.2	1.2	1.2	1.2